



Addendum No. 2

Project Name:	CB Cedar Ave. RWM Replacement and Lift Station 7 Force Main Upsize	Client:	City of Cocoa Beach
Project Location:	Cocoa Beach	Client Representative:	Brad Kalsow
Project Number:	450500-200200.01	Mead & Hunt, Inc. Manager:	Brad Blais, PE
Date:	February 11, 2021	Mead & Hunt Inc. Phone:	386-761-6810

TO ALL BIDDERS: You are requested to make all changes and/or additions contained in this Addendum to the Bidding Documents. Failure to acknowledge this Addendum in Proposal shall result in rejection of bid.

BID DATE AND TIME SHOULD CORRESPOND TO DATE AND TIME INDICATED IN ADVERTISEMENT FOR BIDS, UNLESS DATE AND TIME HAS BEEN CHANGED IN THIS OR PREVIOUS ADDENDUMS.

I. GENERAL

Bids will be received until **February 16th, 2021 @ 2:30 PM.**

II. SPECIFICATIONS

Section 00300 – Proposal is revised and attached to Addendum 2.

Section 00800B – Certification of Compliance with FDEP Supplementary Conditions has been removed. This Section is not required for this project.

Section 00800C – Buy American Certification has been removed. This Section is not required for this project.

Section 00800D – Davis Bacon Certification Form has been removed. This Section is not required for this project.

Section 02 06 14 – Geotechnical Data Report is revised to include the Geotechnical Report.

Section 33 05 07.13 - Utility Directional Drilling is revised and attached to Addendum 2.

III. PLANS

QUESTIONS

1. There is missing form in the Spec Book. The FDEP Supplementary Conditions (00800B-15) is not in Appendix A and this form is listed as one of the required forms on page 00300-3.

Answer: Section 00800B - Certification of Compliance with FDEP Supplementary Conditions is not required. The reference to this section has been removed from Section 00300.

2. Are the Bid dates and times correct?

Answer: The bid opening date has been changed to February 16th, 2021 at 2:30 PM.

3. Would Certa-Lok be approved as an equal to FPVC for the HDD portions of the project Cedar Ave. RWM Replacement and Lift Station 7 Force Main Upsize? Certa-Lok is in the specifications listed in Section 33 05 07.13 Utility Directional Drilling, Section 2.02 Pipe, Section B: PVC Pipe.

Answer: Certa-Lok is not approved. Section 33 05 07.13 has been revised to reflect this.

4. On page 02 06 14-1 of the Cedar Avenue spec book (Adobe page 258), it states that a Geotechnical report is available in the contract documents; however, neither of these documents is in the spec book.

Answer: Geotechnical Report attached in Addendum 2.

END OF ADDENDUM

Disclaimer: This addendum was posted on Vendor Link (www.demandstar.com). It is the sole responsibility of the bidder to confirm that all addenda have been received prior to submitting bid and acknowledge such in the bid documents.

SECTION 00300

PROPOSAL

FOR

**CB CEDAR AVE. RWM REPLACEMENT AND LIFT STATION 7 FM UPSIZE
BID NO. CB21-001**

Bidder's Name: _____

Submitted: _____, 20____

City of Cocoa Beach
Finance Department
Post Office Box 322430
Cocoa Beach, FL 32932

Gentlemen:

The undersigned, as Bidder, hereby declares that the only person or persons interested in the Proposal, as principal or principals, is or are named herein and that no other persons than herein mentioned has any interest in the Proposal or the Contract to which the work pertains; that this Proposal is made without connection or arrangement with any other person, company, or parties making a bid or proposal and that the Proposal is in all respects fair and made in good faith without collusion or fraud.

The Bidder further declares that he has examined the site of the work and that from personal knowledge and experience, or that he/she has made sufficient test holes and/or other subsurface investigations to fully satisfy self that such site is a correct and suitable one for this work and he/she assumes full responsibility therefore; that he/she is familiar with all legal requirements (Federal, State and local laws, ordinances, rules and regulations) pertaining to the Work; that he/she has examined the Drawings and Specifications for the work and from his/her own experience or from professional advice that the Drawings and Specifications are sufficient for the work to be done and he/she has examined the other Contract Documents and all addenda relating thereto, and that he/she has satisfied himself fully, relative to all matters and conditions with respect to the work to which this Proposal pertains.

The Bidder proposes and agrees, if this Proposal is accepted, to contract with the City of Cocoa Beach, (Owner) in the form of contract specified, to furnish all necessary materials, equipment, machinery, tools, apparatus, transportation, and labor and to perform all work necessary to complete the Work specified in the Proposal and other Contract Documents.

The Bidder further proposes and agrees to comply in all respects with the time limits for commencement and completion of the Work as stated in the Contract Form.

The Bidder further agrees that the deductions for liquidated damages, as stated in the Contract Form, constitute fixed and agreed liquidated damages to reimburse the Owner for additional

costs to the Owner resulting from the Work not being completed within the time limit stated in the Contract Form.

The Bidder further agrees to execute a Contract and furnish satisfactory Performance and Payment Bonds, each in the amount of one-hundred percent of the Contract price, and the required Certificates of Insurance, within ten consecutive calendar days after written notice being given by the Owner of the award of the Contract, and the undersigned agrees that in case of failure on his/her part to execute the said Contract, Performance and Payment Bonds and Insurance Certificates within ten (10) consecutive calendar days after the award of the Contract, the bid guarantee accompanying his/her bid and the money payable thereon shall be paid to the Owner as liquidation of damages sustained by the Owner; otherwise, the bid guarantee shall be returned to the undersigned within fifteen days after the Contract is signed and the Performance and Payment Bonds and Insurance Certificates are filed.

The undersigned agrees to accept as full compensation for completion of the project in full compliance with the Contract Documents, the unit prices for the items named in Section 00310, Schedule of Unit Prices, submitted herein with this Proposal.

The undersigned offers to furnish all materials, equipment and labor for construction of, **CB CEDAR AVE. RWM REPLACEMENT AND LIFT STATION 7 FM UPSIZE, BID NO. CB21-001** for the City of Cocoa Beach, Florida, complete in every respect in strict accordance with the drawings, specifications and any future changes therein. The Contractor shall perform these obligations for the prices listed in the "Schedule of Unit Prices: Section 00310" attached and made a part of this Bid. The estimated bid total:

Total Bid: _____
(Dollars)

(In Words)

\$ _____
(In Figures)

1.01 COMPLETION TIME OF CONTRACT

- A. The Contractor agrees that the work shall be started not later than the date indicated in the Notice to Proceed (NTP) and that the total project will be completed within 240 days (**Two hundred Forty Days following the NTP.**)
- B. The Contractor further agrees that for each calendar day, with the exception of Sundays and legal holidays that any work shall remain uncompleted after the completion time stipulated above the sum of **\$1000 (One Thousand Dollars)** shall be deducted from monies due the contractor, not as a penalty, but as liquidated damages. If the Contractor is declared in default in accordance with the provisions of the Specifications, liquidated damages shall be charged as provided herein, and such amounts shall be deducted from the final amount payable to the Contractor or his/her Surety. Should the total amount chargeable

as liquidated damages exceed the amount due or payable to the Contractor or his/her Surety, then such excess shall be paid to the Owner by the Contractor or his/her Surety.

1.02 SUPPLEMENTAL REQUIREMENTS

- A. The following documents are required to be attached to and made a condition of this bid:
1. Project Form & Certification: Section 00030
 2. Proposal: Section 00300 including Acknowledgement of Addenda
 3. Schedule of Unit Prices: Section 00310
 4. Listing of Subcontractors: Section 00330
 5. Listing of Previous Experience: Section 00331
 6. Prime/Subcontractor Form: Section 00332
 7. Bid Bond: Section 00410
 8. Davis Bacon Certification Form: Section 00420
 9. Public Entity Crimes Statement: Section 00470
 10. Anti-Collusion Statement: Section 00480
 11. Drug Free/Tie Preference Statement: Section 00485
 12. Trench Safety Affidavit: Section 00490
 13. Certificate as to Corporate Principal: Section 00620
 14. City of Cocoa Beach's Insurance Requirements: Section 00800A

1.03 REQUIRED DISCLOSURE

- A. Public entity crimes statement form as enclosed herein shall be submitted with each bid.
- B. At its sole discretion, the City of Cocoa Beach, Florida may reject any bidder the City finds to lack, or whose present or former executive employees, officers, directors, stockholders, partners or owners are found by the City to lack honesty, integrity, or moral responsibility. The discretion of the City may be exercised based on the City's own investigation, public records, or any other reliable sources of information. By submitting a bid, bidder recognizes and accepts that the City may reject the bid based upon the exercise of its sole discretion and bidder waives any claim it might have for damages or other relief resulting from the rejection of its bid based on these grounds.
- C. The City will require the CONTRACTOR perform not less than fifty (50) percent of the work with its own forces (i.e., without subcontracting). The fifty (50) percent requirement shall be understood to refer to the work, the value of which totals not less than fifty (50) percent of the Contract Price. Submittal of Section 00332 (Prime/Subcontractor Form) will document the percentage of work performed by Prime Contractor and Sub-Contractor.

1.04 SCHEDULE OF MAJOR MANUFACTURERS AND SUPPLIERS

- A. The equipment manufacturers/suppliers on this project shall be as delineated in the following schedule. Bidders should note that the Owner and Engineer have made rigorous investigations of equipment performance and features, and as a result, Bidders are to note that the contract price for this project shall be based on Base Bid equipment. The Base Bid equipment for this project falls under one of two categories. The first category is equipment that the Owner and Engineer have determined will be supplied by a sole source of supply, for which no substitutions or alternates will be entertained or allowed. Bidder is advised that offering of any alternatives to the sole source supplied equipment will be grounds for rejection of his bid as not responsive. The second category of equipment includes those items where the Owner and Engineer deem there to be more than one acceptable supplier of the particular item listed. The equipment which falls under these two categories is shown on the subsequent pages of this Schedule of Major Manufacturers and Suppliers. Bidder is advised that the award of this Contract will be based solely on the use of Base Bid equipment.

- B. The following comments relate only to the second category of equipment, where the Contract Documents are based upon the equipment or products available from the suppliers denoted as A, B, C, etc. below. These equipment manufacturers, along with the sole source suppliers constitute the Base Bid.

- C. Provision is made in the Contract Documents for alternate manufacturers and suppliers whose equipment or product may be deemed equivalent in quality (see General Conditions). However, the Bidder must indicate in his Bid which Base Bid supplier he intends to use for each item of equipment listed by circling one of the listed manufacturers/suppliers. If the Bidder fails to indicate which listed manufacturer/supplier he intends to use if an alternate is rejected, he must use the supplier listed as "A". Also, if the Bidder circles more than one listed supplier, he must use the first supplier circled (unless an alternate is approved).

- D. If the Bidder desires to propose one or more alternate manufacturers/suppliers, he may write in the name of such alternates in the spaces provided on the Alternate Manufactures/Suppliers page following the schedule. He must, nevertheless, also circle one of the listed manufacturers/suppliers because Bidders' Bid price must be based upon this Base Bid list. Wherever an alternate supplier is proposed, the Bidder must insert the amount to be deducted from the Contract Price (either lump sum or unit price) if the alternate supplier is eventually approved. If the proposed alternate supplier is determined "not equivalent" by the Engineer, the Bidder must use the circled supplier.

ACKNOWLEDGMENT OF ADDENDA

Addenda will be issued via email and it is the Bidder's responsibility to confirm that all addenda have been received prior to submitting a bid for the project. Acknowledgment is hereby made of the following Addenda received since issuance of Drawings and Specifications:

Addendum No. _____	Dated: _____	Addendum No. _____	Dated: _____
Addendum No. _____	Dated: _____	Addendum No. _____	Dated: _____
Addendum No. _____	Dated: _____	Addendum No. _____	Dated: _____

Attached hereto is a cashier's check on the _____ Bank of _____ or Bid Bond for the sum of _____ Dollars (_____), made payable to _____ (Owner).

(Name of Bidder) (Affix Seal)

(Signature of Officer)

(Title of Officer)

Name of Bidder

Address

City/State/Zip

Telephone

Contractor's Florida License Number

The full names and residences of persons and firms interested in the foregoing bid, as principals, are as follows:

END OF SECTION

SECTION 02 06 14
GEOTECHNICAL DATA REPORT

PART 1 - GENERAL

1.01 DESCRIPTION

- A. Geotechnical Data Report information is included in a report prepared for the Owner and the Engineer by the Geotechnical Consultant. The report is reproduced in the contract documents.
- B. The boring data sheet has been used by the Engineer for the design of the foundations for the structures included in the Project.
- C. The subsurface information contained therein was obtained for design purposes and may not be an adequate representation of actual conditions for project construction. Information shown, including water levels, represents existing conditions at the specific boring locations at the time the borings were made. All risks resulting from use or interpretation of the subsurface data shown shall be borne by the Contractor.
- D. This data is available for information only and may be useful as a guide in estimating and planning the work.
- E. If additional subsurface information is required by the Bidder it shall be the Bidder's responsibility to obtain such data.
- F. Refer to the GENERAL CONDITIONS for further explanation of subsurface conditions.

PART 2 - PRODUCTS (Not Used)

PART 3 - EXECUTION (Not Used)

END OF SECTION

**Subsurface Soil Exploration and
Geotechnical Engineering Evaluation
Reuse Water Main
Cedar Avenue
Cocoa Beach, Florida**

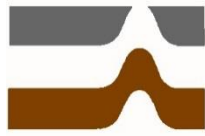

Ardaman & Associates, Inc.

CORPORATE HEADQUARTERS

8008 S. Orange Avenue, Orlando, FL 32809 - Phone: (407) 855-3860 Fax: (407) 859-8121

Branch Office Locations

Florida: Bartow, Cocoa, Fort Myers, Miami, Orlando, Port St. Lucie, Sarasota, Tallahassee, Tampa, West Palm Beach
Louisiana: Baton Rouge, Monroe, New Orleans, Shreveport

MEMBERS:

ASTM International
American Concrete Institute
Geoprofessional Business Association
Society of American Military Engineers
American Council of Engineering Companies



Ardaman & Associates, Inc.

Geotechnical, Environmental and
Materials Consultants

April 23, 2020
File No. 20-23-5224

Mead & Hunt
4401 Eastport Parkway
Port Orange, Florida 32127

Attention: Mr. Brad Blais, PE

Subject: Subsurface Soil Exploration and
Geotechnical Engineering Evaluation
Reuse Water Main
Cedar Avenue and Catalina Road
Cocoa Beach, Florida
Mead & Hunt Project No.: 4505000-200200.01, Phase 3

Dear Mr. Blais:

As requested, we have completed a subsurface soil exploration and geotechnical engineering evaluation for the subject project. The purpose of performing this exploration was to determine if the soil characteristics are suitable to construct the proposed pipeline. In addition, we have estimated the normal seasonal high groundwater table level at the boring locations. This report documents our field exploration and presents our engineering recommendations.

SITE LOCATION AND PROPOSED CONSTRUCTION

The project site includes right-of-way areas along Cedar Avenue and Catalina Road from Minutemen Causeway on the south end of the project to Cocoa Isles Boulevard on the north end of the project in Cocoa Beach, Brevard County, Florida (Section 10, Township 25 South, Range 37 East). The general site location is shown superimposed on the Cocoa Beach, Florida USGS quadrangle map presented on Figure 1.

Our field exploration program was performed in grassed right-of-way areas, as well as within the existing asphalt paved roadways when necessary for drilling access.

Based on our review of information provided by Mead & Hunt, the project includes the installation of approximately 4,450 lineal feet of reuse water main pipe within the right-of-way areas along Cedar Avenue and Catalina Road. The new pipeline will be installed using directional drill procedures. The depth to the bottom of the pipes to be installed within the project area is anticipated to not exceed 8 feet below existing ground surface.

REVIEW OF SOIL SURVEY MAPS

Based on the 1974 Soil Survey for Brevard County, Florida, as prepared by the U.S. Department of Agriculture Soil Conservation Service, the project site is located in an area mapped as the

“Galveston Urban land complex” soil series. A description of this soil type, as obtained from the Soil Survey, is provided below.

Galveston-Urban land complex (Ga):

“Galveston-Urban land complex” soils are well drained Galveston sand and sandy soils that consist of reworked and leveled sandy materials that resemble Galveston sand. The typical soil profile for Galveston sand consists of sand with shell to 80 inches according to the Soil Survey. The water table generally is below a depth of 60 inches; it is between 40 and 60 inches for short periods during the rainy season.

FIELD EXPLORATION PROGRAM

SPT Borings

The field exploration program consisted of performing nine Standard Penetration Test (SPT) borings in proposed pipeline areas. Due to the potential presence of underground utilities in the project area, the top 4.5 feet of each boring was drilled using a 3-inch diameter, hand-held bucket auger. Below 4.5 feet, the SPT borings were advanced a depth of 10.5 feet below the ground surface using the methodology outlined in ASTM D-1586. A summary of this field procedure is included in Appendix I. Soil samples recovered during performance of the SPT borings were visually classified in the field and representative portions of the samples were transported to our laboratory in sealed sample jars for further classification.

The groundwater level at each of the boring locations was measured during drilling. Upon completion of drilling, the boreholes were grouted with neat cement grout and the core holes within the pavement surface were filled with hand compacted cold patch asphalt where borings were drilled within the pavement.

Test Locations

The approximate locations of the borings are summarized on the Boring Location Plan, Figure 2. These locations were determined in the field by estimating distances from existing site features and should be considered accurate only to the degree implied by the method of measurement used.

LABORATORY PROGRAM

Representative soil samples obtained during our field sampling operation were packaged and transferred to our laboratory for further visual examination and classification. The soil samples were visually classified in general accordance with the Unified Soil Classification System (ASTM D-2488). The resulting soil descriptions are shown on the soil boring profiles presented in Appendix II.

GENERAL SUBSURFACE CONDITIONS

General Soil Profile

The results of the field exploration and laboratory programs are graphically summarized on the soil boring profiles presented in Appendix II. The stratification of the boring profiles represents our interpretation of the field boring logs and the results of laboratory examinations of the recovered

samples. The stratification lines represent the approximate boundary between soil types. The actual transitions may be more gradual than implied.

In general, the SPT borings conducted at the project site encountered loose to dense fine sand (Unified Soil Classification SP), fine sand with silt (SP-SM), and silty fine sand (SM) to the boring termination depth of 10.5 feet below existing ground surface. Silty fine sand with wood debris was encountered in Borings TH-3 and TH-5 at depths ranging from approximately 3 to 4 feet below existing ground surface. Various amounts of shell were encountered in the samples collected from the borings. Soils with a high shell content, designated with the term "and shell" on the soil boring profiles in Appendix II, were encountered in Borings TH-1, TH-4, and TH-6 through TH-9 at depths ranging approximately 1.5 to 10.5 feet below existing ground surface. Additionally, partially-cemented sand and shell soil (possible coquina-type soil) was encountered in soil samples collected from Borings TH-4 and TH-9 at depths ranging from approximately 3 to 4.5 feet below existing ground surface.

The above soil profile is outlined in general terms only. Please refer to Appendix II for soil profile details.

Measured Groundwater Level

The groundwater level was measured in the boreholes on the day drilled. As shown in Appendix II, the groundwater level was encountered in the borings at depths ranging from approximately 2.7 to 3.8 feet below existing ground surface on the date drilled. Fluctuations in groundwater levels should be anticipated throughout the year primarily due to seasonal variations in rainfall and other factors that may vary from the time the borings were conducted.

NORMAL SEASONAL HIGH GROUNDWATER LEVEL

The normal seasonal high groundwater level each year is the level in the August-September period at the end of the rainy season during a year of normal (average) rainfall. The water table elevations associated with a higher than normal rainfall and in the extreme case, flood, would be higher to much higher than the normal seasonal high groundwater level. The normal high water levels would more approximate the normal seasonal high groundwater levels.

The seasonal high groundwater level is affected by a number of factors. The drainage characteristics of the soils, the land surface elevation, relief points such as drainage ditches, lakes, rivers, swamp areas, etc., and distance to relief points are some of the more important factors influencing the seasonal high groundwater level.

In addition to evaluating the conditions above, we have reviewed annual precipitation data available from the Melbourne Office of the National Weather Service. Based on this data, the rainfall to date in Brevard County is 4.4 inches, which is approximately 4.3 inches below normal for this time of year.

Based on our interpretation of the site conditions using our boring logs, we estimate the normal seasonal high groundwater level at the boring locations to be approximately 1 foot above the groundwater levels measured at the time of our field exploration.

ENGINEERING EVALUATION AND RECOMMENDATIONS

The results of our exploration indicate that the existing soils, with the exception of the soil containing wood debris, are suitable for supporting the proposed pipeline.

Silty fine sand (Soil Stratum No. 3 in Appendix II) containing wood debris was encountered in Borings TH-3 and TH-5 at depths ranging from approximately 3 to 4 feet below existing ground surface. The soil containing wood debris is not suitable for pipeline support and we recommend that the pipes in the vicinity of these two borings be installed to a depth(s) below the soil containing wood debris using the directional drill procedures.

Other than the silty fine sand containing wood debris, the soils encountered in the SPT borings conducted on the project site consisted mostly of loose to medium dense fine sand and fine sand with silt (Soil Strata Nos. 1 and 2) from existing ground surface to the termination depth of the borings, 10.5 feet below existing ground surface. The only soil encountered in the borings that was dense based on the SPT "N" values obtained during drilling was the fine sand encountered in Boring TH-3 from approximately 9 to 10.5 feet below existing ground surface.

The loose to medium dense soils encountered in the borings should be suitable for the proposed directional drill pipeline installation procedures. The dense soils encountered in the bottom of Boring TH-3 could be difficult to penetrate using the directional drill procedures.

It is noted that soils with a high shell content, designated with the term "and shell" on the soil boring profiles in Appendix II, were encountered in Borings TH-1, TH-4, and TH-6 through TH-9 at depths ranging approximately 1.5 to 10.5 feet below existing ground surface. Additionally, partially-cemented sand and shell soil (possible coquina-type soil) was encountered in soil samples collected from Borings TH-4 and TH-9 at depths ranging from approximately 3 to 4.5 feet below existing ground surface. As previously discussed, the soils containing a high shell content and the soils with partially-cemented sand and shell were loose to medium dense based on the SPT "N" values obtained during drilling. Based on these SPT "N" values, the directional drill installation of the pipeline should be accomplished with typical effort. However, if a significant amount of these soils are found to be partially-cemented (coquina-type soils) during installation, difficulties may arise. The contractor should be prepared for such difficulties during the directional drill pipeline installation.

CLOSURE

The conclusions and recommendations submitted herein are based on the data obtained from the soil borings presented on Figure 2 and in Appendix II. This report does not reflect any variations which may occur adjacent to or between the borings. The nature and extent of the variations between the borings may not become evident until during construction. If variations then appear evident, it will be necessary to re-evaluate the recommendations in this report after performing on-site observations during the construction period and noting the characteristics of any variations.

This report has been prepared for the exclusive use of Mead & Hunt in accordance with generally accepted geotechnical engineering practices. No other warranty, expressed or implied, is made. In the event any changes occur in the design, nature, or location of the proposed pipeline, we should review the applicability of conclusions and recommendations in this report. We also recommend a general review of final design and specifications by our office to make sure that

pipeline installation commendations are properly interpreted and implemented in the design specifications.

We are pleased to be of assistance to you on this project. When we may be of further service to you or should you have any questions, please contact us.

Very truly yours,
ARDAMAN & ASSOCIATES, INC.
Certificate of Authorization No. 5950



Dustin M. Cone
Assistant Project Engineer

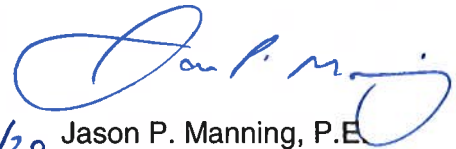

4/23/20 Jason P. Manning, P.E.
Branch Manager
Florida License No. 53265

DMC/JPM/dk

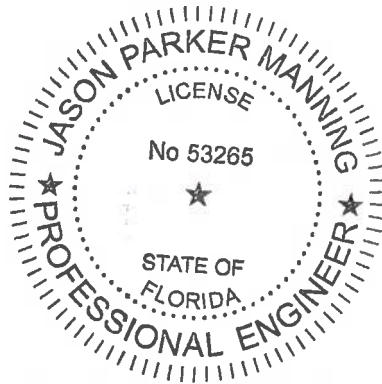

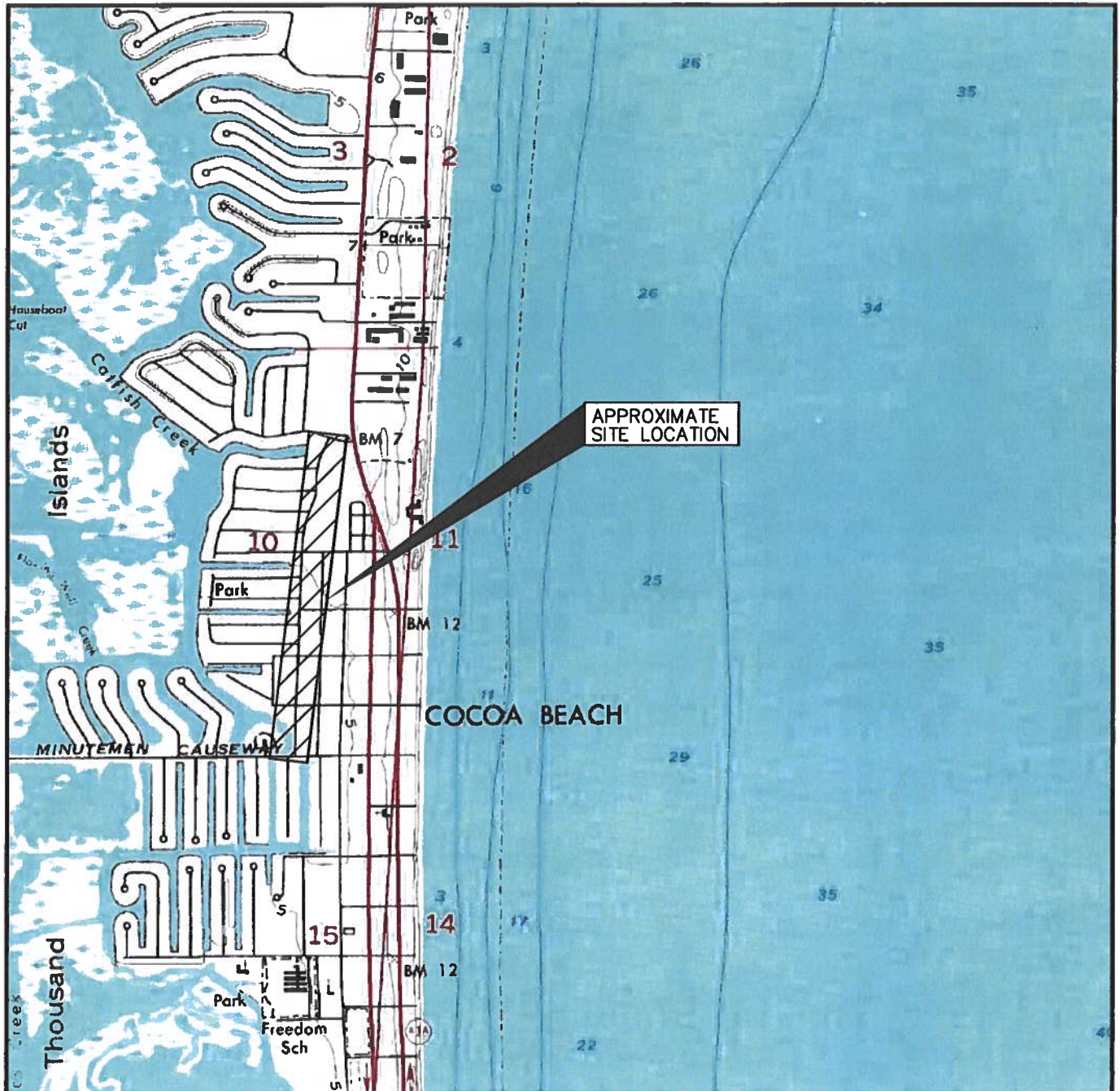

SECTION 10
TOWNSHIP 25 SOUTH
RANGE 37 EAST

OBTAINED FROM U.S.G.S. QUAD MAP: COCOA BEACH, FLORIDA

C:\CAD working files\20-5224\20522401.dwg 4/16/2020 2:28:28 PM tom.taylor

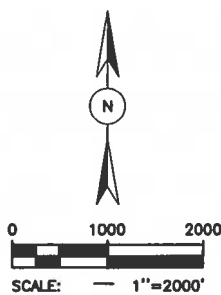

QUADRANGLE LOCATION

SITE LOCATION MAP

Ardaman & Associates, Inc.
Geotechnical, Environmental and
Materials Consultants

SUBSURFACE SOIL EXPLORATION
CEDAR AVENUE REUSE WATER MAIN
COCO A BEACH, FLORIDA

DRAWN BY: TAT	CHECKED BY:	DATE: 4/16/20
FILE NO. 20-5224	APPROVED BY:	FIGURE: 1



LEGEND

⊕ TH STANDARD PENETRATION TEST (SPT)
BORING LOCATION

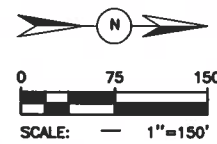

BORING LOCATION PLAN

Ardaman & Associates, Inc.
Geotechnical, Environmental and
Materials Consultants

SUBSURFACE SOIL EXPLORATION
CEDAR AVENUE REUSE WATER MAIN
COCOA BEACH, FLORIDA

DRAWN BY: TT	CHECKED BY:	DATE: 4/16/20
FILE NO. 20-5224	APPROVED BY:	FIGURE: 2

APPENDIX I

Standard Penetration Test Procedure

STANDARD PENETRATION TEST

The standard penetration test is a widely accepted test method of *in situ* testing of foundation soils (ASTM D 1586). A 2-foot long, 2-inch O.D. split-barrel sampler attached to the end of a string of drilling rods is driven 18 inches into the ground by successive blows of a 140-pound hammer freely dropping 30 inches. The number of blows needed for each 6 inches of penetration is recorded. The sum of the blows required for penetration of the second and third 6-inch increments of penetration constitutes the test result or N-value. After the test, the sampler is extracted from the ground and opened to allow visual examination and classification of the retained soil sample. The N-value has been empirically correlated with various soil properties allowing a conservative estimate of the behavior of soils under load.

The tests are usually performed at 5-foot intervals. However, more frequent or continuous testing is done by our firm through depths where a more accurate definition of the soils is required. The test holes are advanced to the test elevations by rotary drilling with a cutting bit, using circulating fluid to remove the cuttings and hold the fine grains in suspension. The circulating fluid, which is a bentonitic drilling mud, is also used to keep the hole open below the water table by maintaining an excess hydrostatic pressure inside the hole. In some soil deposits, particularly highly pervious ones, NX-size flush-coupled casing must be driven to just above the testing depth to keep the hole open and/or prevent the loss of circulating fluid.



Representative split-spoon samples from the soils at every 5 feet of drilled depth and from every different stratum are brought to our laboratory in air-tight jars for further evaluation and testing, if necessary. Samples not used in testing are stored for 30 days prior to being discarded. After completion of a test boring, the hole is kept open until a steady state groundwater level is recorded. The hole is then sealed, if necessary, and backfilled.

APPENDIX II

Soil Boring Profiles

LEGEND

SOIL DESCRIPTIONS

-  ① FINE SAND (SP)
-  ② FINE SAND WITH SILT (SP-SM)
-  ③ SILTY FINE SAND (SM)

COLORS

- Ⓐ LIGHT BROWN TO BROWN
- Ⓑ LIGHT GRAY TO GRAY
- Ⓒ DARK GRAY OR DARK BROWN
- Ⓓ GRAYISH-BROWN

TH STANDARD PENETRATION TEST (SPT) BORING

N STANDARD PENETRATION RESISTANCE IN BLOWS PER FOOT

 GROUNDWATER LEVEL MEASURED ON DATE DRILLED

SP, SP-SM
SM, SC, CH

UNIFIED SOIL CLASSIFICATION SYSTEM

ENGINEERING CLASSIFICATION

I COHESIONLESS SOILS

DESCRIPTION	BLOW COUNT "N"
VERY LOOSE	0 TO 4
LOOSE	4 TO 10
MEDIUM DENSE	10 TO 30
DENSE	30 TO 50
VERY DENSE	>50

WHILE THE BORINGS ARE REPRESENTATIVE OF SUBSURFACE CONDITIONS AT THEIR RESPECTIVE LOCATIONS AND FOR THEIR RESPECTIVE VERTICAL REACHES, LOCAL VARIATIONS CHARACTERISTIC OF THE SUBSURFACE MATERIALS OF THE REGION ARE ANTICIPATED AND MAY BE ENCOUNTERED. THE BORING LOGS AND RELATED INFORMATION ARE BASED ON THE DRILLER'S LOGS AND VISUAL EXAMINATION OF SELECTED SAMPLES IN THE LABORATORY. THE DELINEATION BETWEEN SOIL TYPES SHOWN ON THE LOGS IS APPROXIMATE AND THE DESCRIPTION REPRESENTS OUR INTERPRETATION OF SUBSURFACE CONDITIONS AT THE DESIGNATED BORING LOCATIONS ON THE PARTICULAR DATE DRILLED.

GROUNDWATER ELEVATIONS SHOWN ON THE BORING LOGS REPRESENT GROUNDWATER SURFACES ENCOUNTERED ON THE DATES SHOWN. FLUCTUATIONS IN WATER TABLE LEVELS SHOULD BE ANTICIPATED THROUGHOUT THE YEAR.

SOIL PROFILES LEGEND



Ardaman & Associates, Inc.
Geotechnical, Environmental and
Materials Consultants

SUBSURFACE SOIL EXPLORATION
CEDAR AVENUE REUSE WATER MAIN
COCOA BEACH, FLORIDA

DRAWN BY: TAT	CHECKED BY:	DATE: 4/16/20	
FILE NO. 20-5224	APPROVED BY:	FIGURE:	

DATE DRILLED:

4/6/20
TH-1

FEET
DEPTH

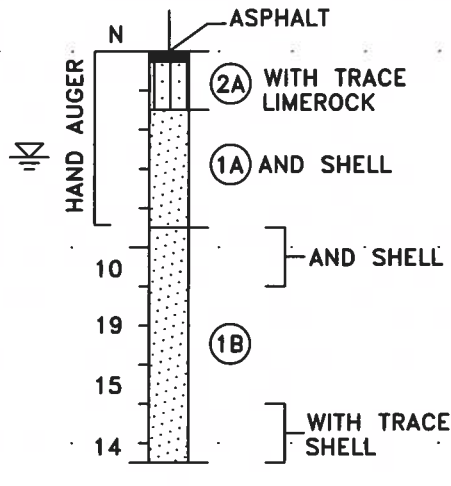

4/6/20
TH-2

FEET
DEPTH

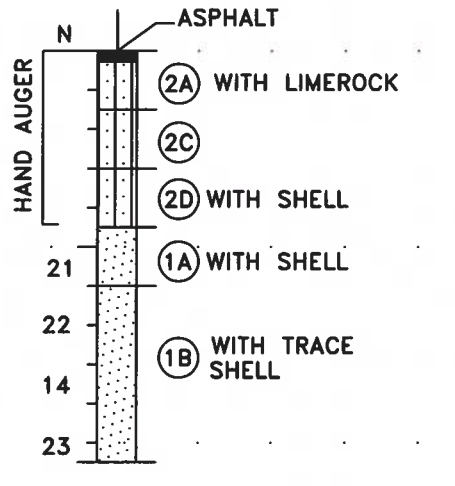

DATE DRILLED:

4/6/20
TH-3

FEET
DEPTH

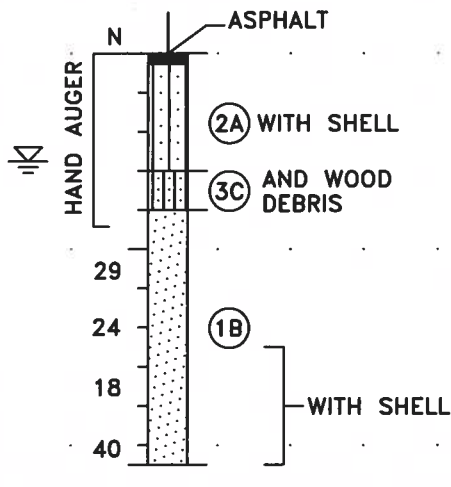

4/6/20
TH-4

FEET
DEPTH

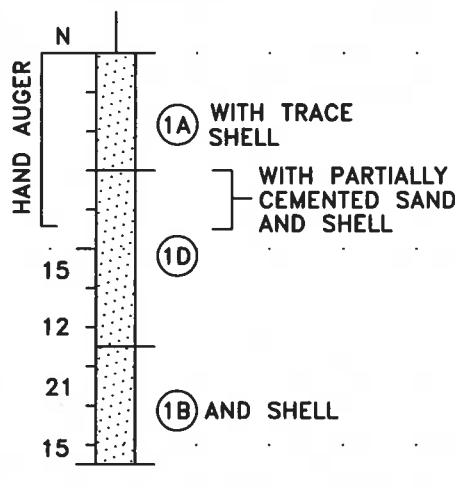

DATE DRILLED:

4/6/20
TH-5

FEET
DEPTH

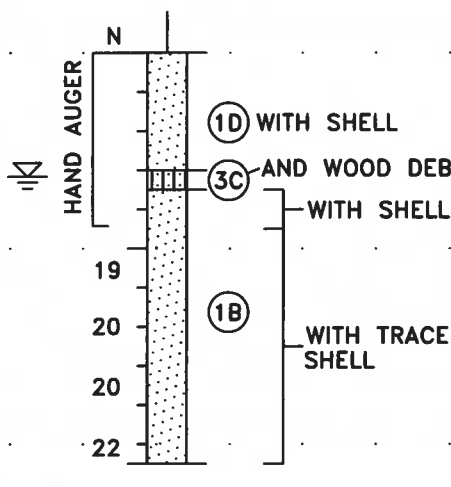

SOIL BORING PROFILES



SUBSURFACE SOIL EXPLORATION
CEDAR AVENUE REUSE WATER MAIN
COCOA BEACH, FLORIDA

DRAWN BY: TAT	CHECKED BY:	DATE: 4/16/20
FILE NO. 20-5224	APPROVED BY:	FIGURE:

DATE DRILLED:

4/6/20
TH-6

DEPTH
FEET

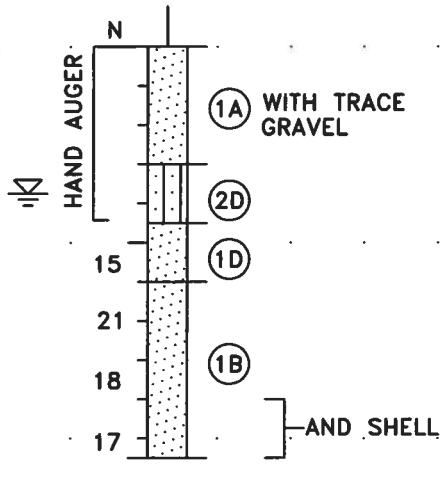

4/6/20
TH-7

DEPTH
FEET

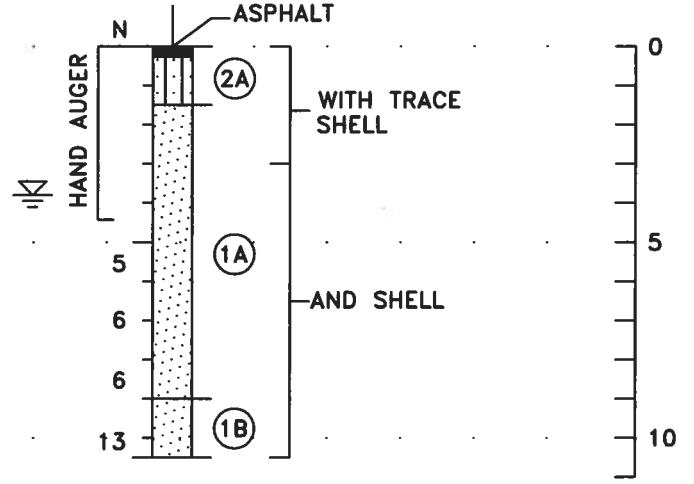

DATE DRILLED:

4/6/20
TH-8

DEPTH
FEET

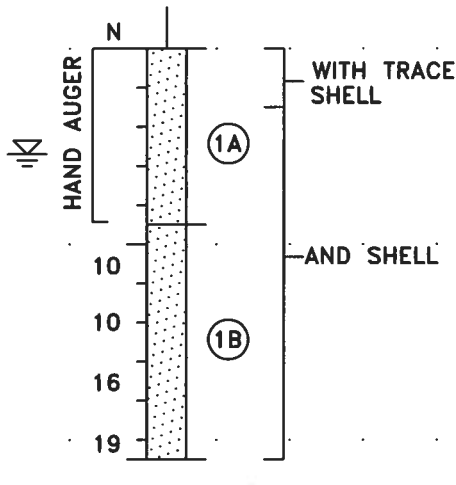

4/6/20
TH-9

DEPTH
FEET

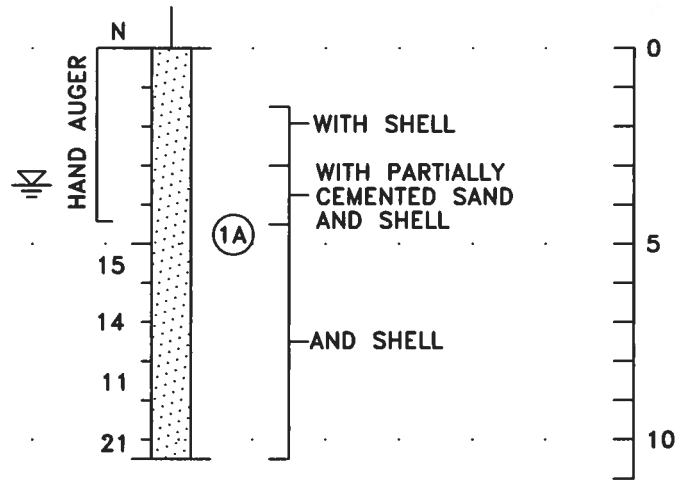

SOIL BORING PROFILES



SUBSURFACE SOIL EXPLORATION
CEDAR AVENUE REUSE WATER MAIN
COCOA BEACH, FLORIDA

DRAWN BY: TAT	CHECKED BY:	DATE: 4/16/20
FILE NO. 20-5224	APPROVED BY:	FIGURE:

SECTION 33 05 07.13
UTILITY DIRECTIONAL DRILL

PART 1 - GENERAL

1.01 DESCRIPTION

- A. SCOPE OF WORK. The work specified in this section consists of furnishing and installing underground utilities using the horizontal directional drilling (HDD) method of installation, also commonly referred to as directional boring or guided horizontal boring. This work shall include all services, equipment, materials, and labor for the complete and proper installation, testing, restoration of underground utilities and environmental protection and restoration.
- B. RELATED WORK SPECIFIED ELSEWHERE
1. Section 01 33 23: Shop Drawings, Product Data, and Samples
 2. Section 01 78 39: Project Record Documents
 3. Section 33 01 00: Operation and Maintenance of Utilities

1.02 QUALITY ASSURANCE

- A. The requirements set forth in this specification specify a wide range of procedural precautions necessary to insure that the very basic, essential aspects of a proper directional bore installation are adequately controlled. Strict adherence shall be required under specifically covered conditions outlined in this specification. Adherence to the specifications contained herein, or the Engineer's approval of any aspect of any directional bore operation covered by this specification, shall in no way relieve the Contractor of their ultimate responsibility for the satisfactory completion of the work authorized under the Contract.

1.03 SUBMITTALS

- A. WORK PLAN. Prior to beginning work, the Contractor must submit to the Engineer a work plan detailing the procedure and schedule to be used to execute the project. The work plan should include a description of all equipment to be used, down-hole tools, a list of personnel and their qualifications and experience (including back-up personnel in the event that an individual is unavailable), list of subcontractors, a schedule of work activity, a safety plan (including MSDS of any potentially hazardous substances to be used), traffic control plan (if applicable), an environmental protection plan and contingency plans for possible

problems. Work plan should be comprehensive, realistic and based on actual working conditions for this particular project. Plan should document the thoughtful planning required to successfully complete the project.

- B. Equipment. Contractor will submit specifications on directional drilling equipment to be used to ensure that the equipment will be adequate to complete the project. Equipment shall include but not be limited to: drilling rig, mud system, mud motors (if applicable), down-hole tools, guidance system, and rig safety systems. Calibration records for guidance equipment shall be included. Specifications for any drilling fluid additives that Contractor intends to use or might use will be submitted.
- C. Material. Specifications on material to be used shall be submitted to Engineer. Material shall include the pipe, fittings, drilling mud, drilling additives and any other item which is to be an installed component of the project or used during construction.
- D. All submittals shall be in conformance with Section 01 33 23.

PART 2 - PRODUCTS

2.01 GENERAL

- A. Directional drilling equipment shall consist of a directional drilling rig of sufficient capacity to perform the bore and pullback the pipe, a drilling fluid mixing, and delivery system of sufficient capacity to successfully complete the crossing; a guidance system to accurately guide boring operations, and trained and competent personnel to operate the system. All equipment shall be in good, safe operating condition with sufficient supplies, materials and spare parts on hand to maintain the system in good working order for the duration of this project.

2.02 PIPE

- A. HDPE Pipe - The pipe shall be high density polyethylene (HDPE) AWWA C906 DR11 with standard ductile iron pipe outer diameters. Where fittings are required, a stainless steel stiffener shall be inserted in the end of the pipe for support. Stiffeners shall be so manufactured by Smith-Blair, Inc. ROMAC, or approved equal. HDPE pipe shall be as manufactured by Plexco, Driscopipe, or approved equal. Pipe shall be color coded for the type of utility service.
- B. PVC Pipe – The pipe shall conform to the requirements in Section 33 01 00 and have restrained joints to allow for pull back of the pipe. Pipe shall be TerraBrute by IPEX, fusible PVC by Underground Solutions, or approved equal.

- C. Ductile Iron Pipe – The pipe shall conform to the requirements in Section 33 01 00 and have restrained joints to allow for pull back of the pipe. Pipe shall be American MT Push Pipe or approved equal.

2.03 DRILLING SYSTEM

- A. Drilling Rig. The directional drilling machine shall consist of a hydraulically powered system to rotate, push and pull hollow drill pipe into the ground at a variable angle while delivering a pressurized fluid mixture to a guidable drill (bore) head. The machine shall be anchored to the ground to withstand the pulling, pushing and rotating pressure required to complete the crossing. The hydraulic power system shall be self-contained with sufficient pressure and volume to power drilling operations. Hydraulic system shall be free of leaks. Rig shall have a system to monitor and record maximum pull-back pressure during pull-back operations. The rig shall be grounded during drilling and pull-back operations. There shall be a system to detect electrical current from the drill string and an audible alarm which automatically sounds when an electrical current is detected.
- B. Drill Head. The drill head shall be steerable by changing its rotation and shall provide the necessary cutting surfaces and drilling fluid jets.
- C. Mud Motors (if required). Mud motors shall be of adequate power to turn the required drilling tools.
- D. Drill Pipe. Shall be constructed of high quality 4130 seamless tubing, grade D or better, with threaded box and pins. Tool joints should be hardened to 32-36 RC.

2.04 GUIDANCE SYSTEM

- A. A conventional electromagnetic sound walkover system, Magnetic Guidance System (MGS) probe or proven gyroscopic probe and interface shall be used to provide a continuous and accurate determination of the location of the drill head during the drilling operation. The guidance shall be capable of tracking at the maximum depth required and in any soil condition, including hard rock. It shall enable the driller to guide the drill head by providing immediate information on the tool face, azimuth (horizontal direction), and inclination (vertical direction). The guidance system shall be accurate to +/-2% of the vertical depth of the borehole at sensing position at depths up to one hundred feet and accurate within 1.5 meters horizontally.
- B. The Guidance System shall be of a proven type and shall be setup and operated by personnel trained and experienced with this system. The Operator shall be aware of any geomagnetic anomalies and shall consider such influences in the operation of the guidance system if using a magnetic system.

2.05 DRILLING FLUID (MUD) SYSTEM

- A. **Mixing System.** A self-contained, closed, drilling fluid mixing system shall be of sufficient size to mix and deliver drilling fluid composed of bentonite clay, potable water and appropriate additives. Mixing system shall be able to molecularly shear individual bentonite particles from the dry powder to avoid clumping and ensure thorough mixing. The drilling fluid reservoir tank shall be a minimum of 500* gallons. Mixing system shall continually agitate the drilling fluid during drilling operations.
- B. **Drilling Fluids.** Drilling fluid shall be composed of clean water and bentonite clay. Water shall be from an authorized source with a pH of 8.5 - 10. Water of a lower pH or with excessive calcium shall be treated with the appropriate amount of sodium carbonate or equal. The water and bentonite clay shall be mixed thoroughly and be absent of any clumps or clods. No additional material may be used in drilling fluid without prior approval from Engineer. Contractor is responsible for provisions to obtain clean water for the fluid.
- C. **The Bentonite mixture used shall have the minimum viscosities as measured by a March Funnel:**
 - 1. Rock, Clay - 60 sec.
 - 2. Hard Clay - 40 sec.
 - 3. Soft Clay - 45 sec.
 - 4. Sandy Clay - 90 sec.
 - 5. Stable Sand - 80 sec.
 - 6. Loose Sand - 110 sec.
 - 7. Wet Sand - 110 sec.
- D. **These viscosities may be varied to best fit the soil conditions encountered, as approved by the Engineer.**
- E. **Additives.** Additives to drilling fluid such as drill soap, polymers, etc. shall be "environmentally safe" and be approved for such usage. No diesel fuel will be used.
- F. **Delivery System.** The mud pumping system shall have a minimum capacity of 50* GPM and be capable of delivering the drilling fluid at a constant minimum pressure of 1000 psi. The delivery system shall have filters in-line to prevent solids from being pumped into the drill pipe. Connections between the pump and drill pipe shall be relatively leak-free. Used

drilling fluid and drilling fluid spilled during drilling operations shall be contained and properly disposed of. A berm, minimum of 12" high, shall be maintained around drill rigs, drilling fluid mixing system, entry and exit pits and drilling fluid recycling system to prevent spills into the surrounding environment. Pumps and or vacuum truck(s) of sufficient size shall be in place to convey excess drilling fluid from containment areas to storage and facilities.

G. (not used)

2.06 OTHER EQUIPMENT

- A. Pipe Rollers. Pipe rollers shall be of sufficient size to fully support the weight of the pipe while being hydro-tested and during pull-back operations. Sufficient number of rollers shall be used to prevent excess sagging of pipe. Rollers shall be used as necessary to assist in pull back operations and in layout/fusing of material.
- B. Pipe Rammers. Hydraulic or pneumatic pipe rammers may only be used if necessary and with the authorization of Engineer.
- C. Restrictions. Other devices or utility placement systems for providing horizontal thrust other than those previously defined in the preceding sections shall not be used unless approved by the Engineer prior to commencement of the work. Consideration for approval will be made on an individual basis for each specified location. The proposed device or system will be evaluated prior to approval or rejection on its potential ability to complete the utility placement satisfactorily without undue stoppage and to maintain line and grade within the tolerances prescribed by the particular conditions of the project.

PART 3 - EXECUTION

3.01 GENERAL

- A. The Engineer must be notified 48 hours in advance of starting work. The Directional Bore shall not begin until the Engineer is present at the job site and agrees that proper preparations for the operation have been made. The Engineer approval for beginning the installation shall in no way relieve the Contractor of the ultimate responsibility for the satisfactory completion of the work as authorized under the Contract.
- B. Existing Utilities. The drawings show existing utilities that are believed to be near the directional drill alignment. There is no guarantee that these utilities are located as shown or that other utilities may not be present. The Contractor is to field locate existing utilities in advance of the work so as not to delay work and avoid conflict and disruption of utility services.

3.02 PERSONNEL REQUIREMENTS

- A. All personnel shall be fully trained in their respective duties as part of the directional drilling crew and in safety. Each person must have at least two years directional drilling experience. A competent and experienced supervisor representing the Contractor and Drilling Subcontractor shall be present at all times during the actual drilling operations. A responsible representative who is thoroughly familiar with the equipment and type work to be performed, must be in direct charge and control of the operation at all times. In all cases the supervisor must be continually present at the job site during the actual Directional Bore operation. The Contractor and Subcontractor shall have a sufficient number of competent workers on the job at all times to insure the Directional Bore is made in a timely and satisfactory manner.
- B. Personnel who are unqualified, incompetent or otherwise not suitable for the performance of this project shall be removed from the jobsite and replaced with a suitable person.

3.03 DRILLING PROCEDURE

- A. Site Preparation. If not completed, prior to any alterations to worksite, contractor shall photograph or video tape entire work area, including entry and exit points. One copy of shall be given to Engineer and one copy to remain with contractor for a period of one year following the completion of the project.
- B. Work site as indicated on drawings, within right-of-way, shall be graded or filled to provide a level working area. No alterations beyond what is required for operations are to be made. Contractor shall confine all activities to designated work areas.
- C. Drill Path Survey. Entire drill path shall be accurately surveyed with entry and exit stakes placed in the appropriate locations within the areas indicated on drawings. If contractor is using a magnetic guidance system, drill path will be surveyed for any surface geomagnetic variations or anomalies.
- D. Environmental Protection. Contractor shall place silt fence between all drilling operations and any drainage, wetland, waterway or other area designated for such protection by contract documents, state, federal and local regulations. Additional environmental protection necessary to contain any hydraulic or drilling fluid spills shall be put in place, including berms, liners, turbidity curtains and other measures. Contractor shall adhere to all applicable environmental regulations. Fuel or oil may not be stored in bulk containers within 200' of any water body or wetland.
- E. Safety. Contractor shall adhere to all applicable state, federal and local safety regulations and all operations shall be conducted in a safe manner. Safety meetings shall be

conducted at least weekly with a written record of attendance and topic submitted to Engineer.

- F. Pipe. Pipe shall be welded/fused together in one length, if space permits. Steel pipe welds will be X-rayed prior to being placed in bore hole. Pipe will be placed on pipe rollers before pulling into bore hole with rollers spaced close enough to prevent excessive sagging of pipe.
- G. Pilot Hole. Pilot hole shall be drilled on bore path with no deviations greater than 5% of depth over a length of 100'. In the event that pilot does deviate from bore path more than 5% of depth in 100', contractor will notify Engineer and Engineer may require contractor to pull-back and re-drill from the location along bore path before the deviation.
- H. In the event that a drilling fluid fracture, inadvertent returns or returns loss occurs during pilot hole drilling operations, Contractor will cease operations and will discuss corrective options and with the Engineer and/or maintaining agency, then work will then proceed accordingly.
- I. Reaming. Upon successful completion of pilot hole, contractor will ream bore hole to a minimum of 25% greater than outside diameter of pipe using the appropriate tools. Contractor will not attempt to ream at one time more than the drilling equipment and mud system are designed to safely handle.
- J. Pull-Back. After successfully reaming bore hole to the required diameter, contractor will pull the pipe through the bore hole. In front of the pipe will be a swivel. Once pull-back operations have commenced, operations must continue without interruption until pipe is completely pulled into bore hole. During pull-back operations contractor will not apply more than the maximum safe pipe pull pressure at any time.
- K. In the event that pipe becomes stuck, contractor will notify Engineer. Engineer, contractor, and/or the maintaining agency will discuss options and then work will proceed accordingly.

3.04 PIPE TESTING

- A. Following successful pull-back of pipe, contractor will hydro-test pipe as required in Section 33 01 00.

3.05 SITE RESTORATION

- A. Following drilling operations, contractor will de-mobilize equipment and restore the work site to original condition. Any noticeable surface defects due to the drilling operation shall be repaired by Contractor.

- B. In areas where directional drill is required to take place under pavement, the following procedures shall be followed to prevent road failure. Upon completion of the drill and pull, the Contractor shall pump the drill pit free of all excess drill mud. This may cause a void between the top of this pipe and the roof of the pre-reamed hole. The Contractor can either over excavate the pit, exposing the top of the pipe in the void area, backfill, and compact to full depth. Alternatively, the pit may be filled with flowable fill to the full sub-base depth. Cover the pipe, fitting, or valves with visqueen, filling the annular space. The Contractor remains responsible for repairing the pavement if subsidence occurs in the pit area within 3 months of completing the work.

3.06 RECORD KEEPING

- A. As-Builts. Contractor shall maintain a daily project log of drilling operations and a guidance system log with a copy given to Engineer at completion of boring. As-built drawings shall be certified as to accuracy by contractor as required in Section 01 78 39.

END OF SECTION